

4

3

2

1

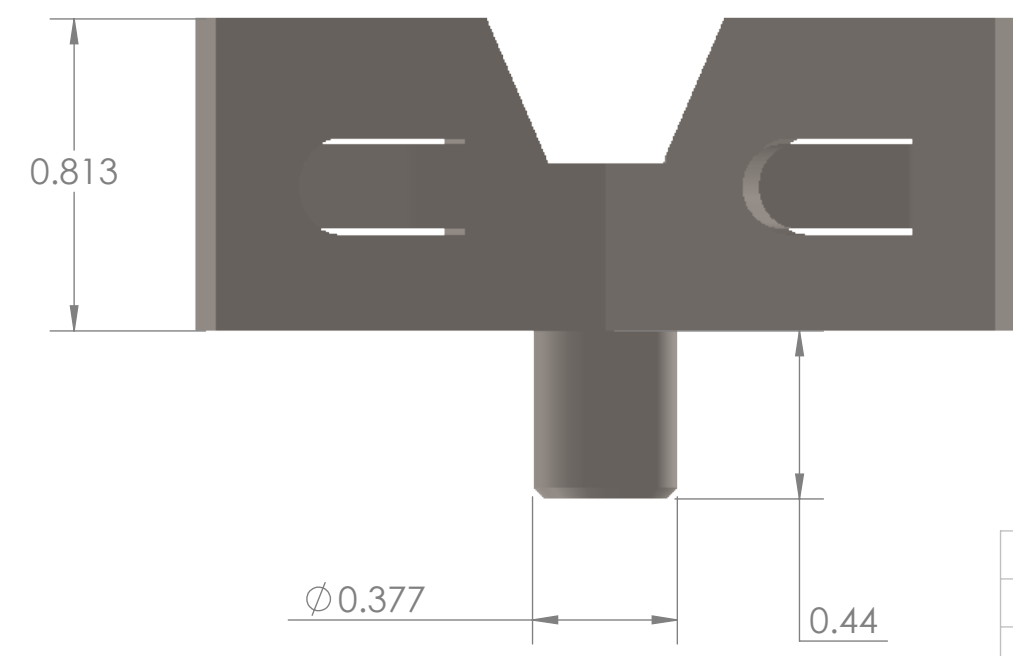
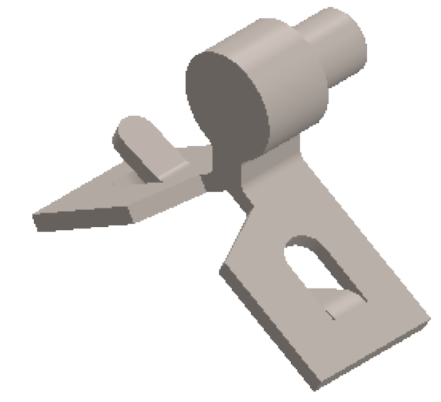
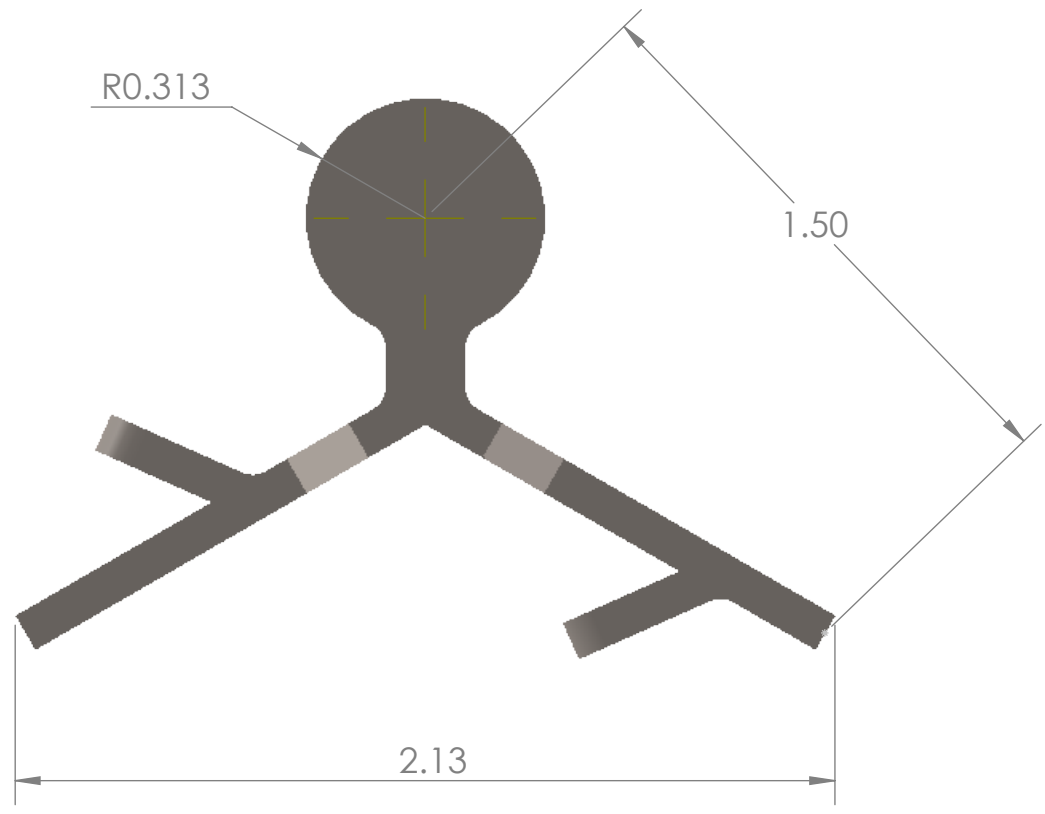

PROPRIETARY AND CONFIDENTIAL
 THE INFORMATION CONTAINED IN THIS DRAWING IS THE SOLE PROPERTY OF MALCO. ANY REPRODUCTION IN PART OR AS A WHOLE WITHOUT THE WRITTEN PERMISSION OF MALCO IS PROHIBITED.

		UNLESS OTHERWISE SPECIFIED:	NAME	DATE		
		DIMENSIONS ARE IN INCHES	DRAWN	MW	3/13/26	TITLE: 
		TOLERANCES:	CHECKED			
		FRACTIONAL \pm	ENG APPR.			
		ANGULAR: MACH \pm BEND \pm	MFG APPR.			
		TWO PLACE DECIMAL \pm	Q.A.			SIZE DWG. NO. REV B SpeedWing 41 0
		THREE PLACE DECIMAL \pm	COMMENTS:			
		INTERPRET GEOMETRIC TOLERANCING PER:				SCALE: 2:1 WEIGHT:
		MATERIAL				SHEET 1 OF 1
NEXT ASSY	USED ON	FINISH				
APPLICATION		DO NOT SCALE DRAWING				

4

3

2

1

B

B

A

A

4

3

2

1

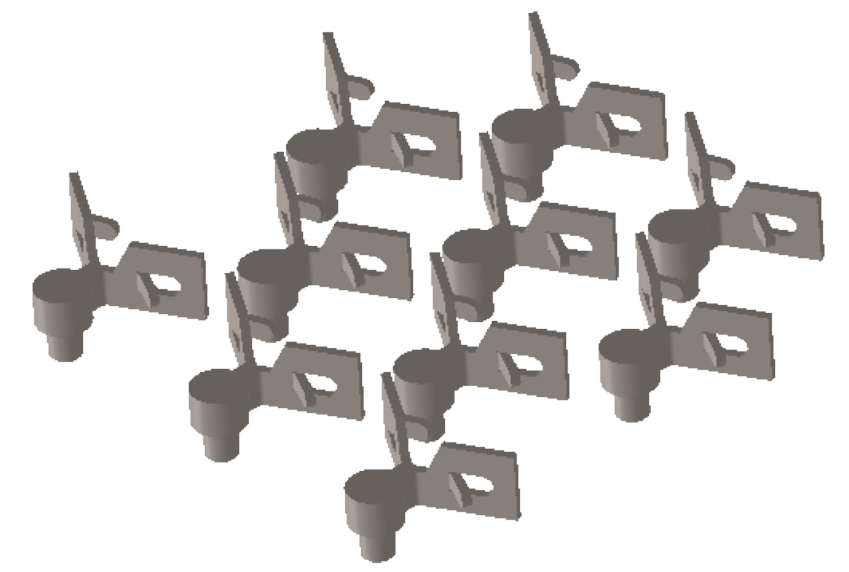
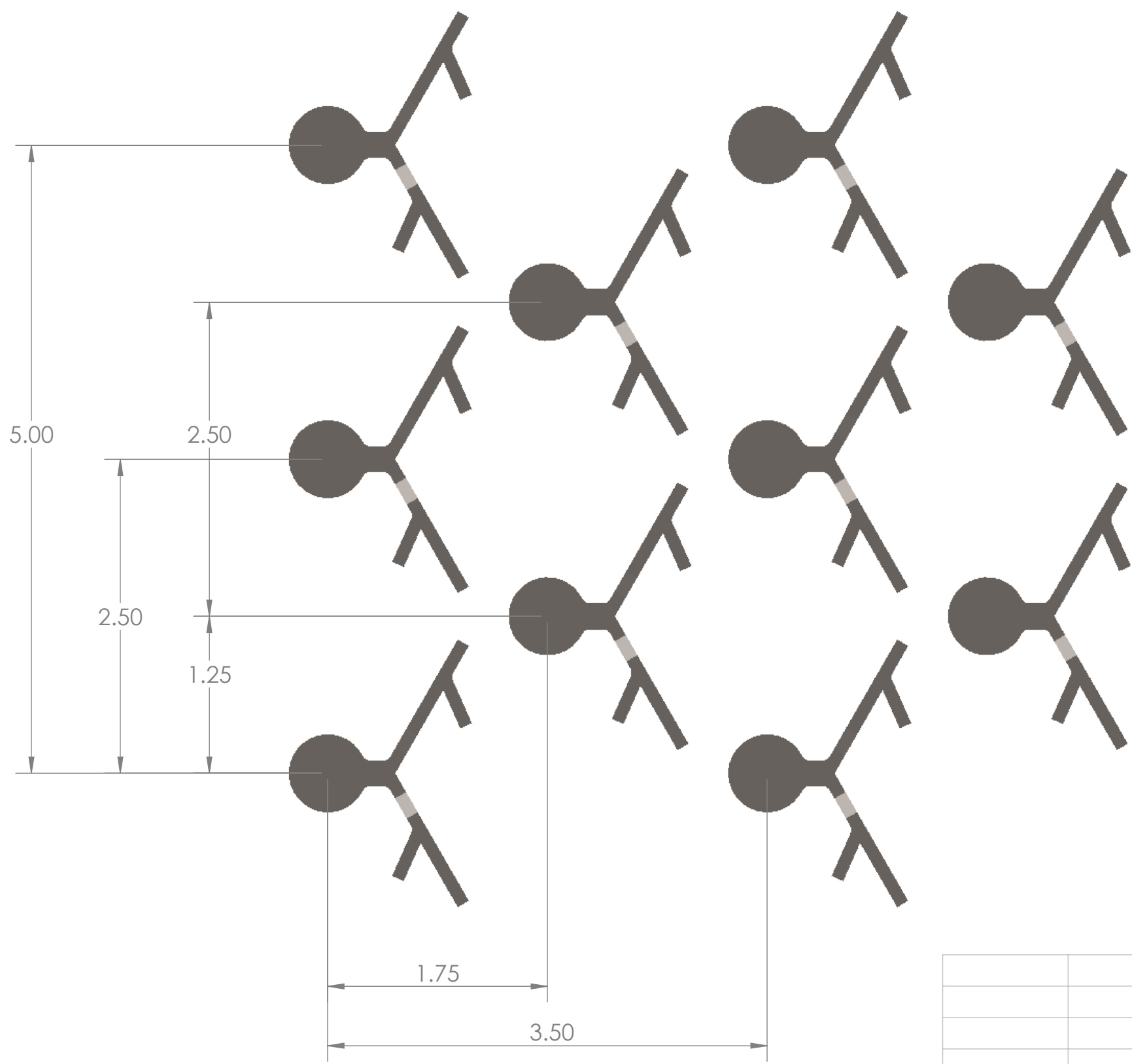

SPEED WING 41 ASSEMBLY 15

PROPRIETARY AND CONFIDENTIAL
 THE INFORMATION CONTAINED IN THIS DRAWING IS THE SOLE PROPERTY OF MALCO. ANY REPRODUCTION IN PART OR AS A WHOLE WITHOUT THE WRITTEN PERMISSION OF MALCO IS PROHIBITED.

		UNLESS OTHERWISE SPECIFIED:		NAME	DATE		
		DIMENSIONS ARE IN INCHES		DRAWN	MW	3/16/26	TITLE:
		TOLERANCES:		CHECKED			
		FRACTIONAL ±		ENG APPR.			
		ANGULAR: MACH ± BEND ±		MFG APPR.			
		TWO PLACE DECIMAL ±		Q.A.			
		THREE PLACE DECIMAL ±		COMMENTS:			
		INTERPRET GEOMETRIC TOLERANCING PER:					SIZE
		MATERIAL					DWG. NO.
		Steel					SpeedWing 41 Assy 15
		FINISH					REV
NEXT ASSY	USED ON						0
APPLICATION		DO NOT SCALE DRAWING					SCALE: 1:1
							WEIGHT:
							SHEET 1 OF 1

4

3

2

1

B

B

A

A