

4

3

2

1

B

B

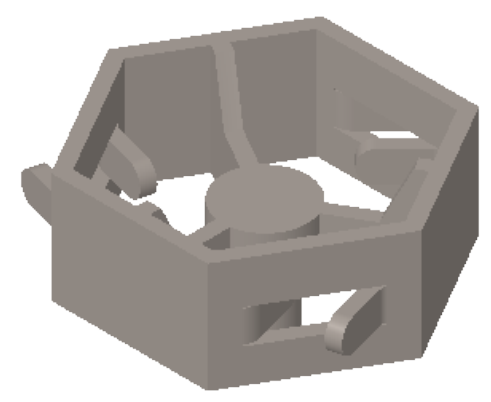
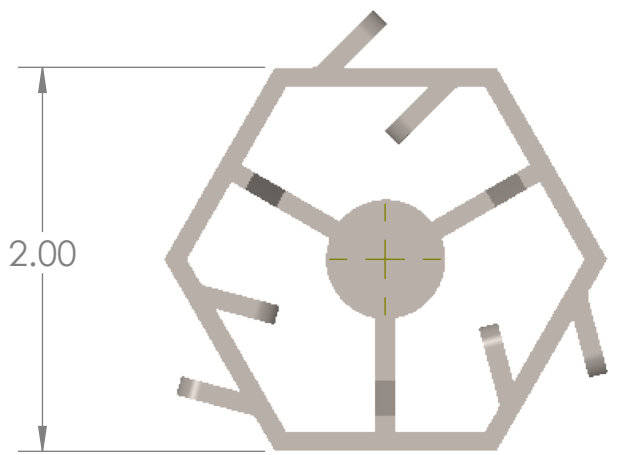

A

A

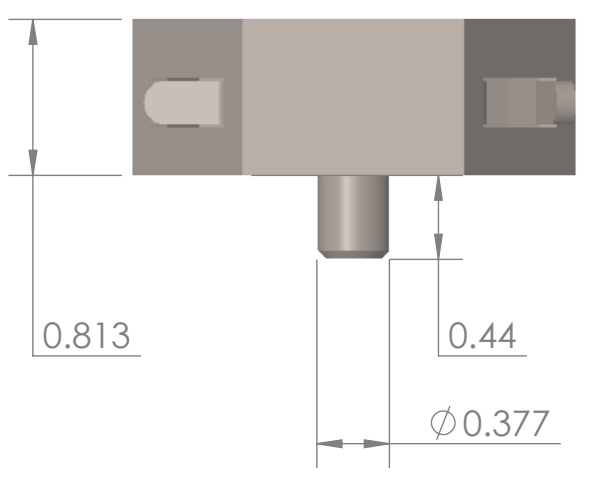

PROPRIETARY AND CONFIDENTIAL
 THE INFORMATION CONTAINED IN THIS
 DRAWING IS THE SOLE PROPERTY OF
 MALCO. ANY REPRODUCTION IN PART
 OR AS A WHOLE WITHOUT THE WRITTEN
 PERMISSION OF MALCO IS PROHIBITED.

		UNLESS OTHERWISE SPECIFIED:		NAME	DATE	
		DIMENSIONS ARE IN INCHES	DRAWN	MW	3/9/26	
		TOLERANCES:	CHECKED			TITLE:
		FRACTIONAL \pm	ENG APPR.			 MALCO
		ANGULAR: MACH \pm BEND \pm	MFG APPR.			
		TWO PLACE DECIMAL \pm	Q.A.			SIZE
		THREE PLACE DECIMAL \pm	COMMENTS:			DWG. NO.
		INTERPRET GEOMETRIC				REV
		TOLERANCING PER:				0
		MATERIAL				SCALE: 1:1
		STEEL				WEIGHT:
		FINISH				SHEET 1 OF 1
NEXT ASSY	USED ON	APPLICATION				
		DO NOT SCALE DRAWING				

4

3

2

1

4

3

2

1

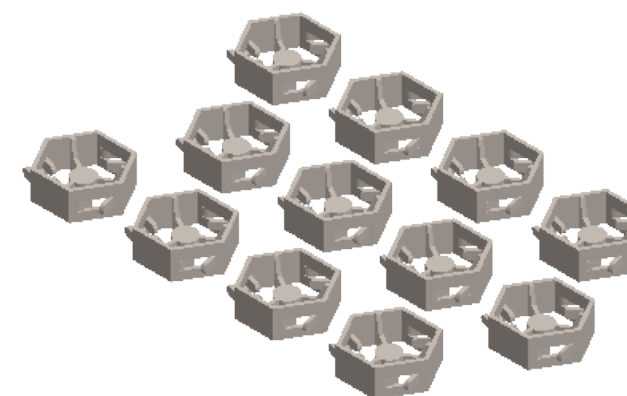
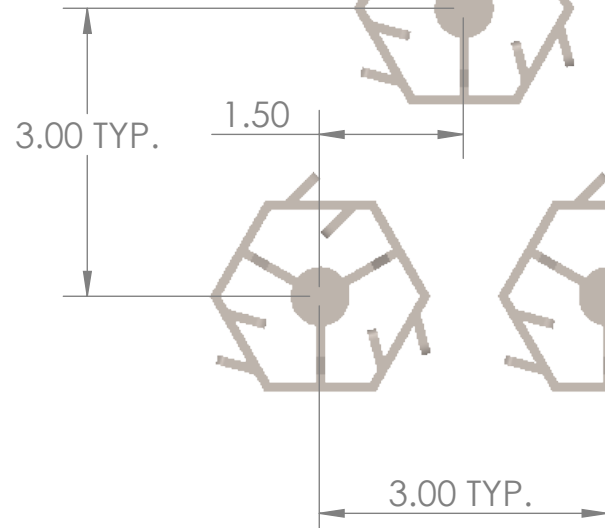

1" CAST HEX ELL ASSEMBLY -20

PROPRIETARY AND CONFIDENTIAL
 THE INFORMATION CONTAINED IN THIS DRAWING IS THE SOLE PROPERTY OF MALCO. ANY REPRODUCTION IN PART OR AS A WHOLE WITHOUT THE WRITTEN PERMISSION OF MALCO IS PROHIBITED.

		UNLESS OTHERWISE SPECIFIED:		NAME	DATE		
		DIMENSIONS ARE IN INCHES		DRAWN	MW	3/16/26	TITLE:
		TOLERANCES:		CHECKED			
		FRACTIONAL: ±		ENG APPR.			
		ANGULAR: MACH ± BEND ±		MFG APPR.			
		TWO PLACE DECIMAL ±		Q.A.			SIZE B DWG. NO. 0D1000 Assy REV 0
		THREE PLACE DECIMAL ±		COMMENTS:			
		INTERPRET GEOMETRIC TOLERANCING PER:				SCALE: 1:2 WEIGHT: SHEET 1 OF 1	
		MATERIAL					
NEXT ASSY	USED ON	FINISH					
APPLICATION		DO NOT SCALE DRAWING					

4

3

2

1

B

B

A

A