

2

1

NO.	A	B	C	D	FERRULE PART NO.
-1	1 1/4	1/4-20	.215	.375	F-250
-2	1 1/2				
-3	1 3/4				
-4	2				
-5	1 1/4	5/16-18	.275	.375	F-312
-6	1 1/2				
-7	1 3/4				
-8	2				
-9	1	3/8-16	.330	.390	F-375
-10	1 1/8				
-11	1 1/4				
-12	1 1/2				
-13	1 3/8				
-14	1 5/8				
-15	1 3/4				
-16	1 1/4	1/2-13	.448	.500	F-500
-17	1 3/8				
-18	1 1/2				
-19	1 5/8				
-20	1 3/4				
-21	1 7/8				
-22	2				

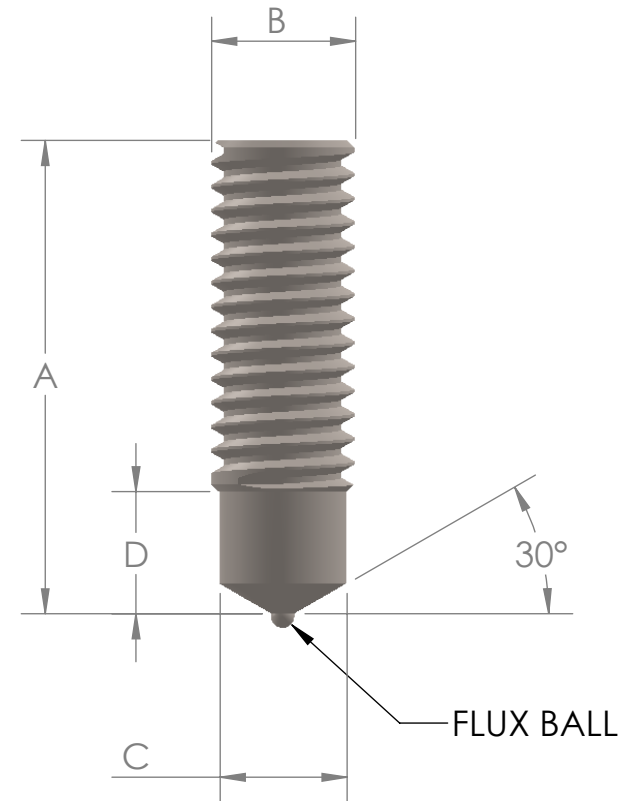

LENGTHS NOT LISTED ABOVE MAY BE OBTAINED BY SPECIFYING IN ORDER

A

A

<p>PROPRIETARY AND CONFIDENTIAL THE INFORMATION CONTAINED IN THIS DRAWING IS THE SOLE PROPERTY OF MALCO. ANY REPRODUCTION IN PART OR AS A WHOLE WITHOUT THE WRITTEN PERMISSION OF MALCO IS PROHIBITED.</p>			UNLESS OTHERWISE SPECIFIED:		NAME	DATE	<p>TITLE:</p> 		
			DIMENSIONS ARE IN INCHES TOLERANCES: FRACTIONAL ± ANGULAR: MACH ± BEND ± TWO PLACE DECIMAL ± THREE PLACE DECIMAL ±	DRAWN	MW	1/7/26			
			INTERPRET GEOMETRIC TOLERANCING PER:	CHECKED					
			MATERIAL Stainless steel	ENG APPR.					
	NEXT ASSY	USED ON	FINISH	MFG APPR.			SIZE	DWG. NO.	REV
				COMMENTS:			A	AS-351	0
	APPLICATION		DO NOT SCALE DRAWING				SCALE: 2:1	WEIGHT:	SHEET 1 OF 1

2

1