

4

3

2

1

NO.	X	BACKUP THICKNESS	
		A	B
-1	1 1/16	1/2	0
-2	1 5/16	3/4	1/4
-3	1 9/16	1	1/2
-4	1 13/16	1 1/4	3/4
-5	2 1/16	1 1/2	1
-6	2 5/16	1 3/4	1 1/4
-7	2 9/16	2	1 1/2
-8	2 13/16	2 1/4	1 3/4
-9	3 1/16	2 1/2	2
-10	3 5/16	2 3/4	2 1/4
-11	3 9/16	3	2 1/2
-12	3 13/16	3 1/4	2 3/4
-13	4 1/16	3 1/2	3
-14	4 5/16	3 3/4	3 1/4
-15	4 9/16	4	3 1/2
-16	4 13/16	4 1/4	3 3/4
-17	5 1/16	4 1/2	4
-18	5 5/16	4 3/4	4 1/4
-19	5 9/16	5	4 1/2
-20	5 13/16	5 1/4	4 3/4
-21	6 1/16	5 1/2	5
-22	6 5/16	5 3/4	5 1/4
-23	6 9/16	6	5 1/2
-24	6 13/16	6 1/4	5 3/4
-25	7 1/16	6 1/2	6
-26	7 5/16	6 3/4	6 1/4
-27	7 9/16	7	6 1/2
-28	7 13/16	7 1/4	6 3/4
-29	8 1/16	7 1/2	7
-30	8 5/16	7 3/4	7 1/4
-31	8 9/16	8	7 1/2
-32	8 13/16	8 1/4	7 3/4
-33	9 1/16	8 1/2	8

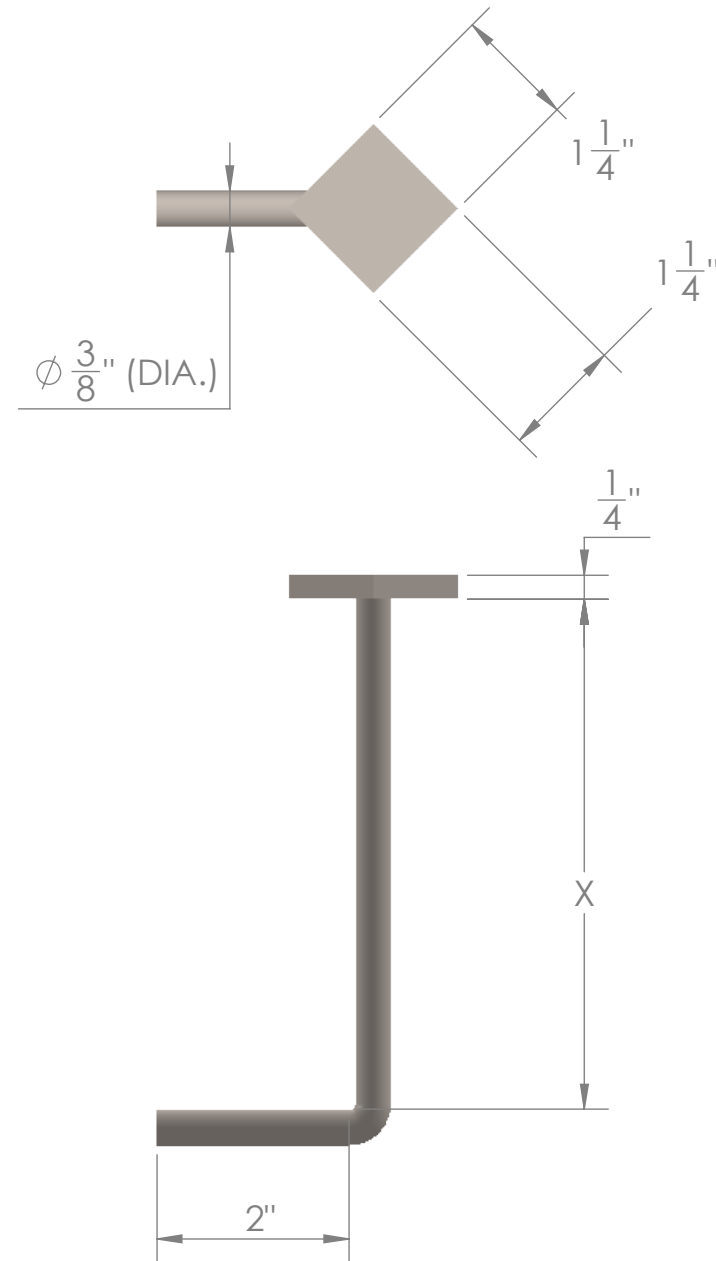

A-FOR 8-43401 ANCHOR  
B-FOR 8-82112 ANCHOR

**PROPRIETARY AND CONFIDENTIAL**  
THE INFORMATION CONTAINED IN THIS DRAWING IS THE SOLE PROPERTY OF MALCO. ANY REPRODUCTION IN PART OR AS A WHOLE WITHOUT THE WRITTEN PERMISSION OF MALCO IS PROHIBITED.

		UNLESS OTHERWISE SPECIFIED:	NAME	DATE	TITLE:	
		DIMENSIONS ARE IN INCHES	DRAWN	MW		1/2/26
		TOLERANCES: FRACTIONAL ± ANGULAR: MACH ± BEND ± TWO PLACE DECIMAL ± THREE PLACE DECIMAL ±	CHECKED			
		INTERPRET GEOMETRIC TOLERANCING PER:	ENG APPR.			
		MATERIAL Stainless steel	MFG APPR.			
		FINISH	Q.A.			
NEXT ASSY	USED ON		COMMENTS:			
APPLICATION		DO NOT SCALE DRAWING				
SIZE	DWG. NO.	REV				
<b>B</b>	AS-272	0				
SCALE: 1:2	WEIGHT:	SHEET 1 OF 1				

4

3

2

1

B

B

A

A