

4

3

2

1

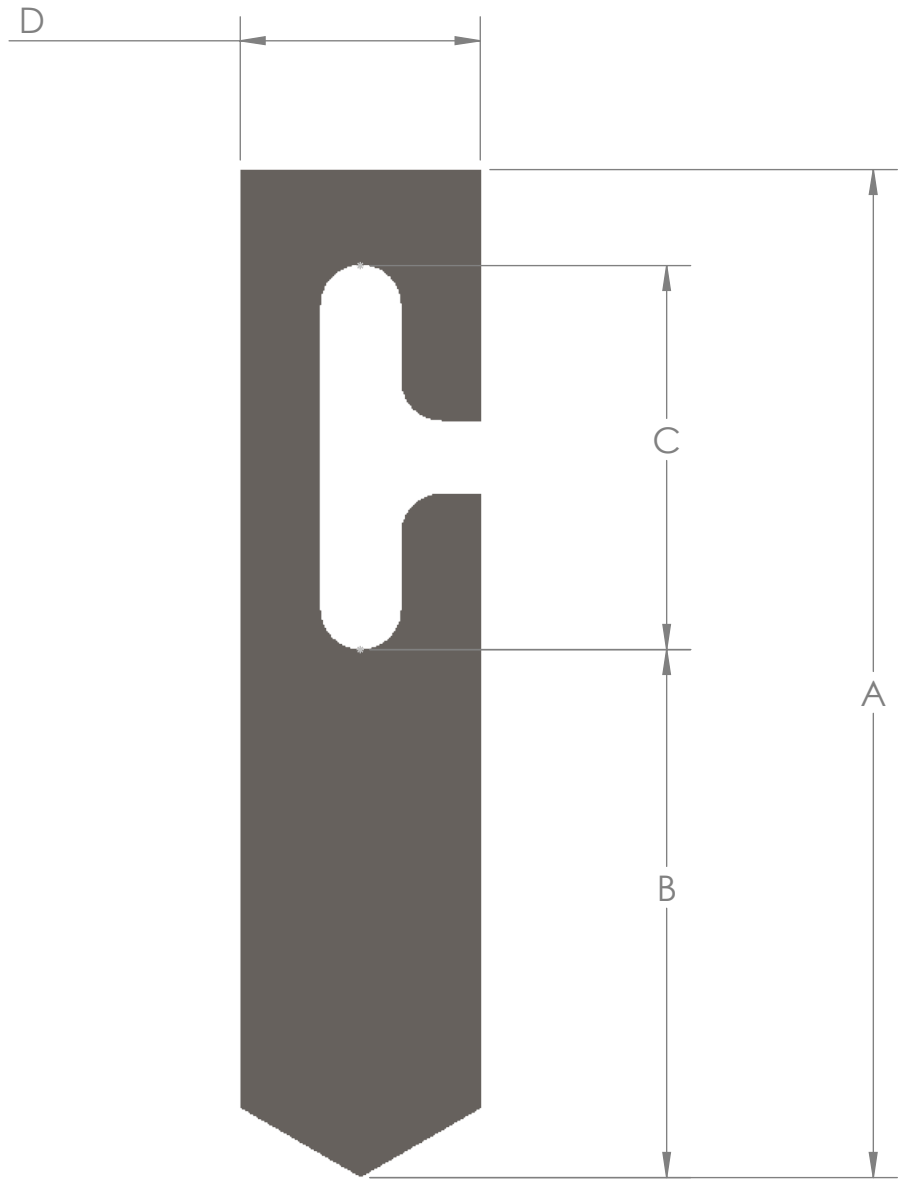

T = THICKNESS

B

B

A

A

NO.	A	B	C	D	T
-1	1 7/8	5/8	1	5/8	1/8
-2	2 1/8	7/8	1	5/8	1/8
-3	2 5/8	1 3/8	1	5/8	1/8
-4	3 1/8	1 7/8	1	5/8	1/8

PROPRIETARY AND CONFIDENTIAL
 THE INFORMATION CONTAINED IN THIS DRAWING IS THE SOLE PROPERTY OF MALCO. ANY REPRODUCTION IN PART OR AS A WHOLE WITHOUT THE WRITTEN PERMISSION OF MALCO IS PROHIBITED.

		UNLESS OTHERWISE SPECIFIED:		NAME	DATE
		DIMENSIONS ARE IN INCHES		DRAWN	MW 12/22/25
		TOLERANCES:		CHECKED	
		FRACTIONAL ±		ENG APPR.	
		ANGULAR: MACH ± BEND ±		MFG APPR.	
		TWO PLACE DECIMAL ±		Q.A.	
		THREE PLACE DECIMAL ±		COMMENTS:	
		INTERPRET GEOMETRIC TOLERANCING PER:			
		MATERIAL			
		Stainless steel			
		FINISH			
NEXT ASSY	USED ON				
APPLICATION		DO NOT SCALE DRAWING			

TITLE:			
SIZE	DWG. NO.		
B	AS-263	0	
SCALE: 2:1	WEIGHT:	SHEET 1 OF 1	

4

3

2

1