

4

3

2

1

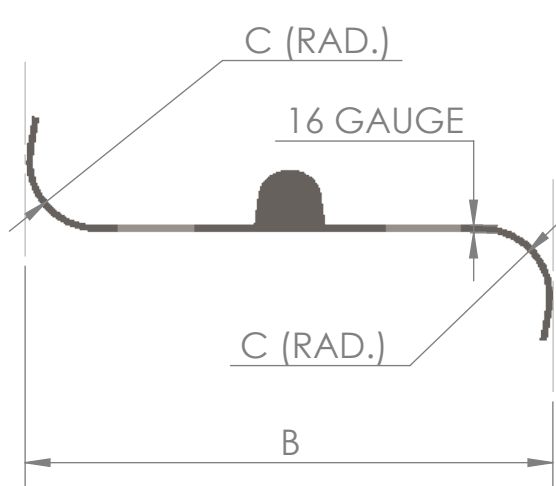
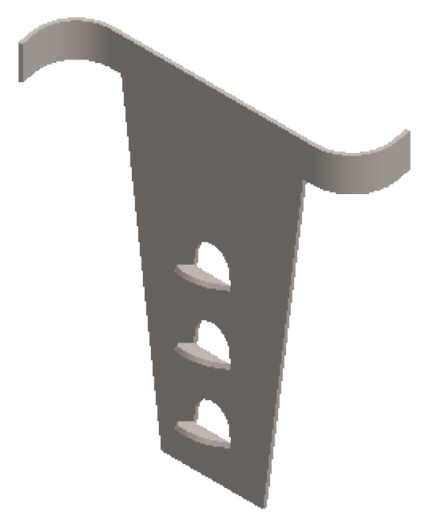
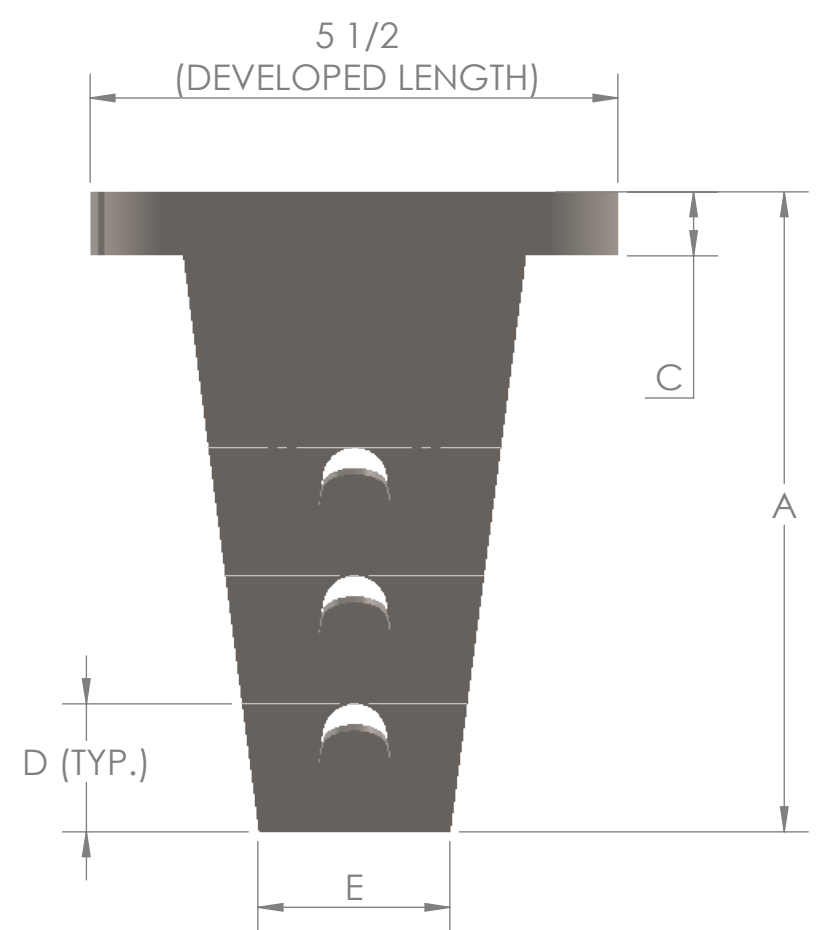

NO.	A	B	C	D	E	TABS
-1	1	4 1/8	1/2	1	1 1/2	1
-2	2	4 1/8	1/2	1	1 1/2	1
-3	3	4 1/8	1/2	1	1 1/2	2
-4	4	4 1/8	1/2	1	1 1/2	2
-5	5	4 1/8	1/2	1	1 1/2	3

PROPRIETARY AND CONFIDENTIAL
 THE INFORMATION CONTAINED IN THIS DRAWING IS THE SOLE PROPERTY OF MALCO. ANY REPRODUCTION IN PART OR AS A WHOLE WITHOUT THE WRITTEN PERMISSION OF MALCO IS PROHIBITED.

		UNLESS OTHERWISE SPECIFIED:	NAME	DATE		
		DIMENSIONS ARE IN INCHES	DRAWN	MW	12/22/25	TITLE:
		TOLERANCES:	CHECKED			
		FRACTIONAL ±	ENG APPR.			
		ANGULAR: MACH ± BEND ±	MFG APPR.			
		TWO PLACE DECIMAL ±	Q.A.			 SIZE DWG. NO. REV B AS-260 0
		THREE PLACE DECIMAL ±	COMMENTS:			
		INTERPRET GEOMETRIC TOLERANCING PER:				
NEXT ASSY	USED ON	MATERIAL Stainless steel				SCALE: 2:3
APPLICATION		FINISH				WEIGHT:
		DO NOT SCALE DRAWING				SHEET 1 OF 1

4

3

2

1

B

B

A

A