

4

3

2

1

NO.	A	B	C	D	E
-1	2	3/4	3/4	60°	1/8
-2	3	3/4	3/4	60°	1/8
-3	6 1/2	3/4	3/4	60°	1/8
-4	1 1/2	3/4	3/4	60°	3/16
-5	2	3/4	3/4	60°	3/16
-6	2 1/4	3/4	3/4	60°	3/16
-7	2 3/4	3/4	3/4	60°	3/16
-8	3 3/4	3/4	3/4	60°	3/16
-9	4 1/2	3/4	3/4	60°	3/16
-10	5 1/2	3/4	3/4	60°	3/16
-11	6 1/2	3/4	3/4	60°	3/16
-12	1 1/2	3/4	3/4	60°	1/4
-13	2 1/4	3/4	3/4	60°	1/4
-14	2 3/4	3/4	3/4	60°	1/4
-15	3 3/4	3/4	3/4	60°	1/4
-16	4 1/2	3/4	3/4	60°	1/4
-17	5 1/2	3/4	3/4	60°	1/4
-18	6 1/2	3/4	3/4	60°	1/4

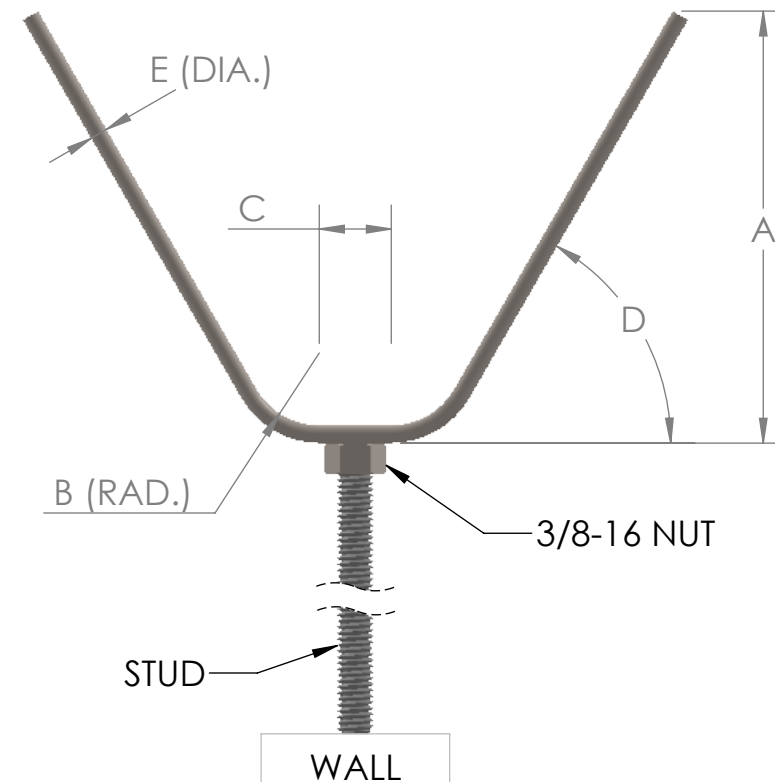

**PROPRIETARY AND CONFIDENTIAL**  
THE INFORMATION CONTAINED IN THIS DRAWING IS THE SOLE PROPERTY OF MALCO. ANY REPRODUCTION IN PART OR AS A WHOLE WITHOUT THE WRITTEN PERMISSION OF MALCO IS PROHIBITED.

UNLESS OTHERWISE SPECIFIED:		NAME	DATE	TITLE:			
DIMENSIONS ARE IN INCHES		DRAWN	MW	12/22/25			
TOLERANCES:		CHECKED					
FRACTIONAL ±		ENG APPR.					
ANGULAR: MACH ± BEND ±		MFG APPR.					
TWO PLACE DECIMAL ±		Q.A.			SIZE	DWG. NO.	REV
THREE PLACE DECIMAL ±		COMMENTS:			<b>B</b>	AR-803-TB	0
INTERPRET GEOMETRIC TOLERANCING PER:					SCALE: 1:2	WEIGHT:	SHEET 1 OF 1
MATERIAL							
Stainless steel							
NEXT ASSY	USED ON						
APPLICATION		DO NOT SCALE DRAWING					

4

3

2

1

B

A