

4

3

2

1

NO.	A	B	C	D	E	F	G	H	I	J	K
-1	1 1/2	-	3	1 5/8	1/4	30°	7/16	15/16	1 1/2	1 1/4	1/2
-2	2	-	3 1/2	1 5/8	1/4	30°	7/16	15/16	1 1/2	1 1/4	1/2
-3	2 1/2	-	4	1 5/8	1/4	30°	7/16	15/16	1 1/2	1 1/4	1/2
-4	3	-	4 1/2	1 5/8	1/4	30°	7/16	15/16	1 1/2	1 1/4	1/2
-5	3 1/2	-	5	1 5/8	1/4	30°	7/16	15/16	1 1/2	1 1/4	1/2
-6	4	-	5 1/2	1 5/8	1/4	30°	7/16	15/16	1 1/2	1 1/4	1/2
-7	4 1/2	-	6	1 5/8	1/4	30°	7/16	15/16	1 1/2	1 1/4	1/2
-8	-	4	6 1/2	1 5/8	1/4	30°	7/16	15/16	1 1/2	1 1/4	1/2
-9	-	4 1/2	7	1 5/8	1/4	30°	7/16	15/16	1 1/2	1 1/4	1/2
-10	-	5	7 1/2	1 5/8	1/4	30°	7/16	15/16	1 1/2	1 1/4	1/2
-11	-	5 1/2	8	1 5/8	1/4	30°	7/16	15/16	1 1/2	1 1/4	1/2
-12	-	6	8 1/2	1 5/8	1/4	30°	7/16	15/16	1 1/2	1 1/4	1/2
-13	-	6 1/2	9	1 5/8	1/4	30°	7/16	15/16	1 1/2	1 1/4	1/2

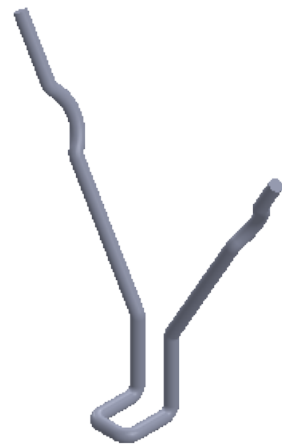
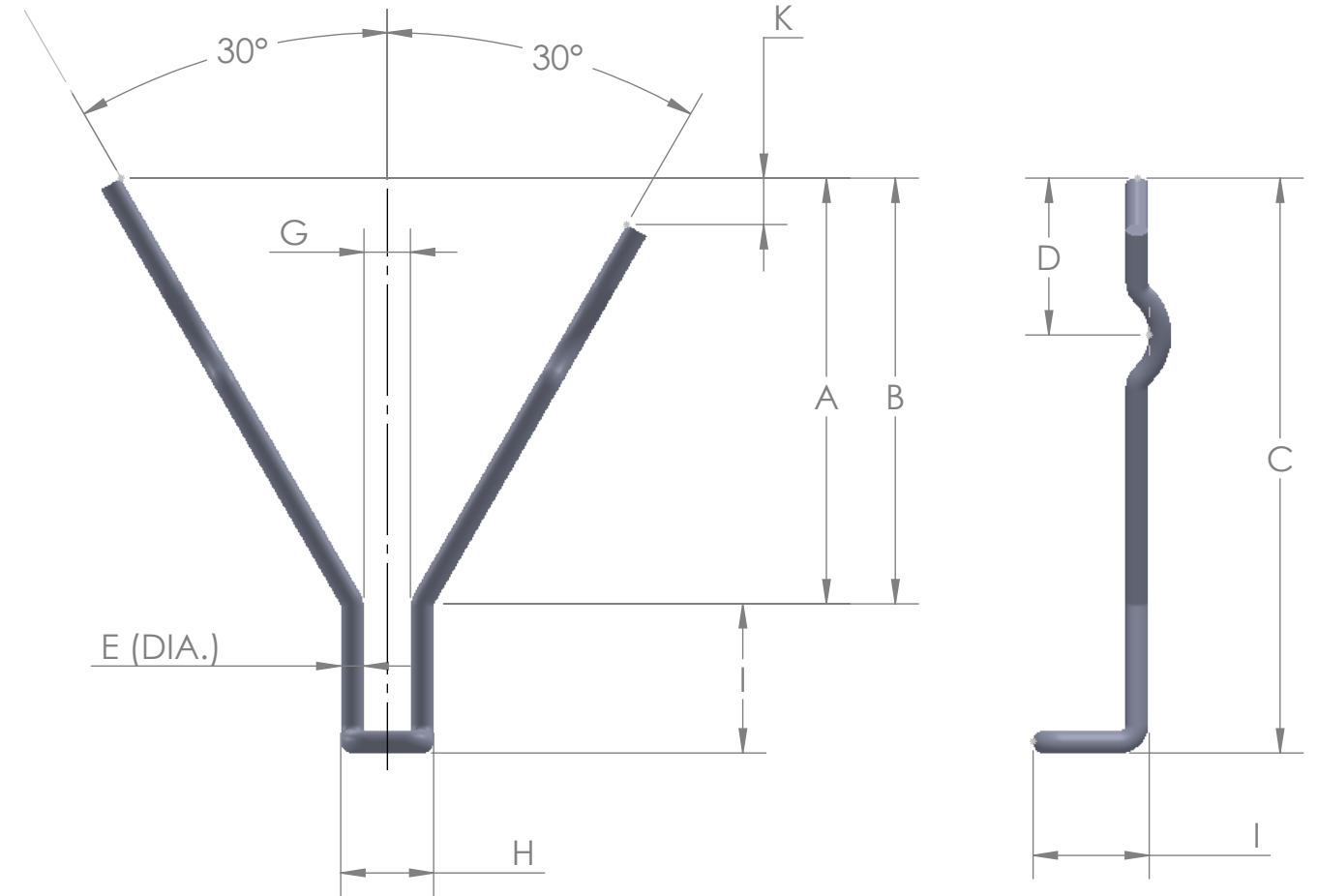

**PROPRIETARY AND CONFIDENTIAL**  
 THE INFORMATION CONTAINED IN THIS DRAWING IS THE SOLE PROPERTY OF MALCO. ANY REPRODUCTION IN PART OR AS A WHOLE WITHOUT THE WRITTEN PERMISSION OF MALCO IS PROHIBITED.

		UNLESS OTHERWISE SPECIFIED:		NAME	DATE
		DIMENSIONS ARE IN INCHES		DRAWN	MW 12/10/25
		TOLERANCES:		CHECKED	
		FRACTIONAL ±		ENG APPR.	
		ANGULAR: MACH ± BEND ±		MFG APPR.	
		TWO PLACE DECIMAL ±		Q.A.	
		THREE PLACE DECIMAL ±		COMMENTS:	
		INTERPRET GEOMETRIC TOLERANCING PER:			
		MATERIAL			
		Stainless steel			
		FINISH			
NEXT ASSY	USED ON				
APPLICATION		DO NOT SCALE DRAWING			
		TITLE:			
					
SIZE	DWG. NO.	REV			
<b>B</b>	<b>AR-753</b>	<b>0</b>			
SCALE: 1:2		WEIGHT:		SHEET 1 OF 1	

4

3

2

1

B

B

A

A