

4

3

2

1

NO.	A	B	C	D	E	F	G	H	I	J	K
-1	2 1/2	-	-	5	2 5/8	5/16	7/16	11/16	1 5/16	30°	1/2
-2	3	-	-	5 1/2	2 5/8	5/16	7/16	11/16	1 5/16	30°	1/2
-3	3 1/2	-	-	6	2 5/8	5/16	7/16	11/16	1 5/16	30°	1/2
-4	4	-	-	6 1/2	2 5/8	5/16	7/16	11/16	1 5/16	30°	1/2
-5	4 1/2	-	-	7	2 5/8	5/16	7/16	11/16	1 5/16	30°	1/2
-6	-	4	-	7 1/2	2 5/8	5/16	7/16	11/16	1 5/16	30°	1/2
-7	-	4 1/2	-	8	2 5/8	5/16	7/16	11/16	1 5/16	30°	1/2
-8	-	5	-	8 1/2	2 5/8	5/16	7/16	11/16	1 5/16	30°	1/2
-9	-	5 1/2	-	9	2 5/8	5/16	7/16	11/16	1 5/16	30°	1/2
-10	-	-	4	9 1/2	2 5/8	5/16	7/16	11/16	1 5/16	30°	1/2
-11	-	-	4 1/2	10	2 5/8	5/16	7/16	11/16	1 5/16	30°	1/2
-12	-	-	5	10 1/2	2 5/8	5/16	7/16	11/16	1 5/16	30°	1/2
-13	-	-	5 1/2	11	2 5/8	5/16	7/16	11/16	1 5/16	30°	1/2
-14	-	-	6	11 1/2	2 5/8	5/16	7/16	11/16	1 5/16	30°	1/2
-15	-	-	6 1/2	12	2 5/8	5/16	7/16	11/16	1 5/16	30°	1/2
-16	-	-	7	12 1/2	2 5/8	5/16	7/16	11/16	1 5/16	30°	1/2
-17	-	-	7 1/2	13	2 5/8	5/16	7/16	11/16	1 5/16	30°	1/2
-18	-	-	8	13 1/2	2 5/8	5/16	7/16	11/16	1 5/16	30°	1/2
-19	-	-	8 1/2	14	2 5/8	5/16	7/16	11/16	1 5/16	30°	1/2
-20	-	-	9	14 1/2	2 5/8	5/16	7/16	11/16	1 5/16	30°	1/2
-21	-	-	9 1/2	15	2 5/8	5/16	7/16	11/16	1 5/16	30°	1/2

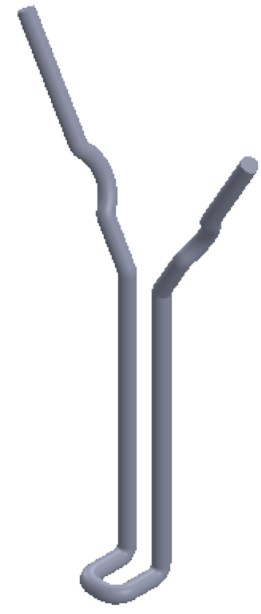
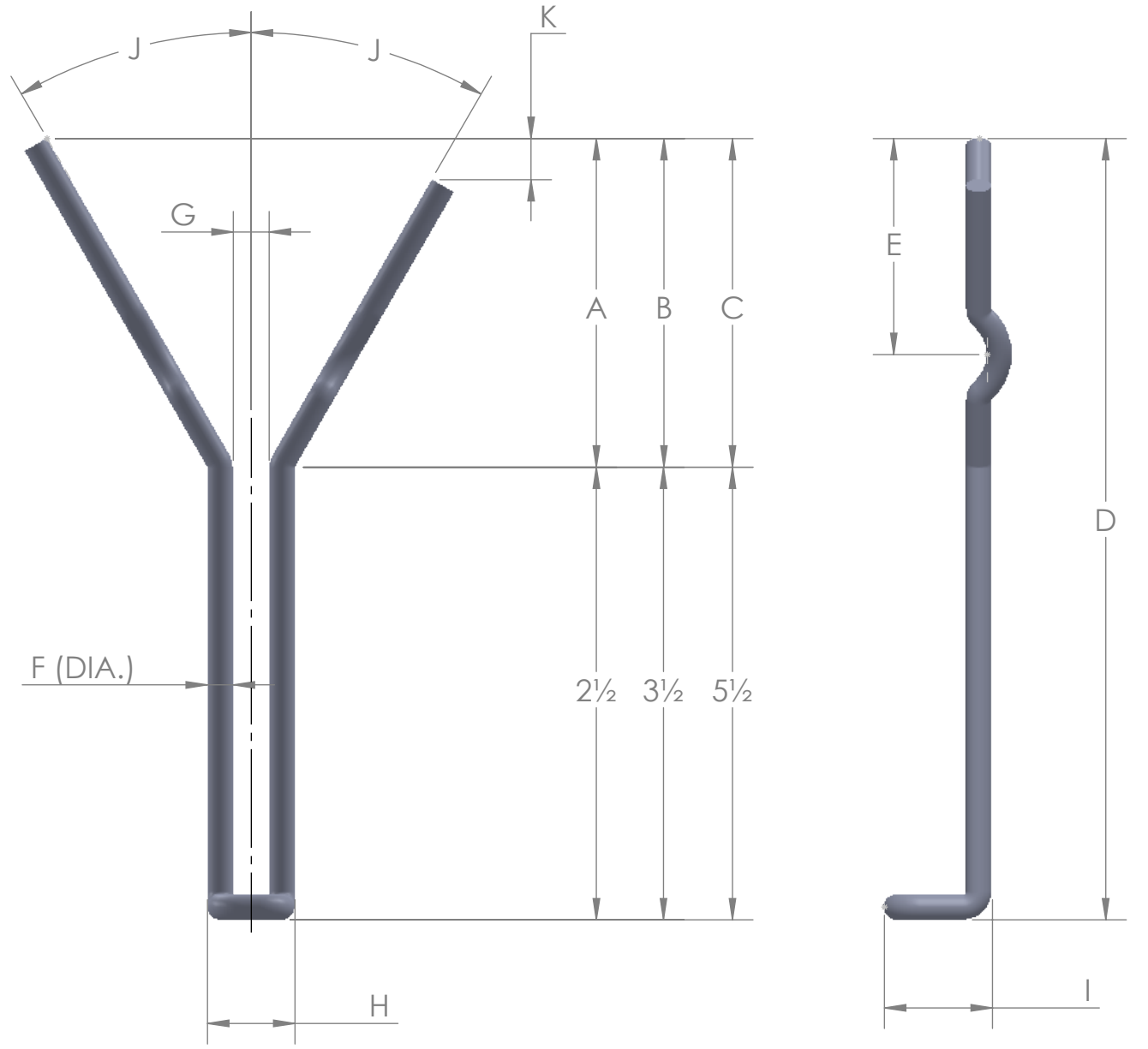

PROPRIETARY AND CONFIDENTIAL
 THE INFORMATION CONTAINED IN THIS DRAWING IS THE SOLE PROPERTY OF MALCO. ANY REPRODUCTION IN PART OR AS A WHOLE WITHOUT THE WRITTEN PERMISSION OF MALCO IS PROHIBITED.

		UNLESS OTHERWISE SPECIFIED:		NAME	DATE
		DIMENSIONS ARE IN INCHES		DRAWN	MW 12/8/25
		TOLERANCES:		CHECKED	
		FRACTIONAL: ±		ENG APPR.	
		ANGULAR: MACH ± BEND ±		MFG APPR.	
		TWO PLACE DECIMAL ±		Q.A.	
		THREE PLACE DECIMAL ±		COMMENTS:	
		INTERPRET GEOMETRIC TOLERANCING PER:			
		MATERIAL			
		Stainless steel			
		FINISH			
NEXT ASSY	USED ON				
APPLICATION		DO NOT SCALE DRAWING			

TITLE:			
SIZE	DWG. NO.		
B	AR-752	REV	0
SCALE: 1:2	WEIGHT:	SHEET 1 OF 1	

4

3

2

1

B

B

A

A