

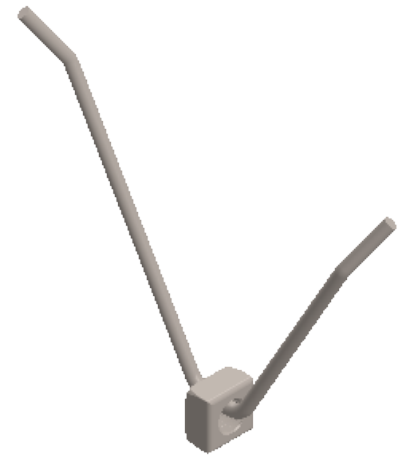

	4		3			2		1
NO.	A	B	C	D	E	F	G	
-1	2	2	60°	1/4	1/2	45°	3/8	
-2	3	2	60°	1/4	1/2	45°	3/8	
-3	4	3	60°	1/4	1/2	45°	3/8	
-4	5	4	60°	1/4	1/2	45°	3/8	
-5	6	5	60°	1/4	1/2	45°	3/8	
-6	7	6	45°	5/16	1/2	45°	3/8	
-7	8	7	45°	5/16	1/2	45°	3/8	
-8	9	8	45°	5/16	1/2	45°	3/8	
-9	10	9	45°	5/16	1/2	45°	3/8	

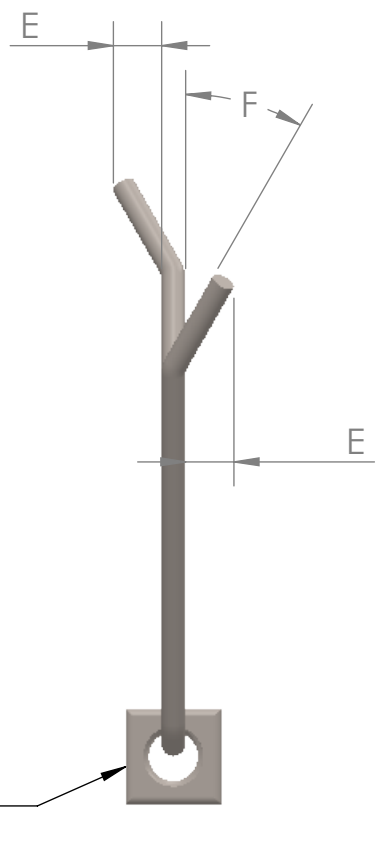
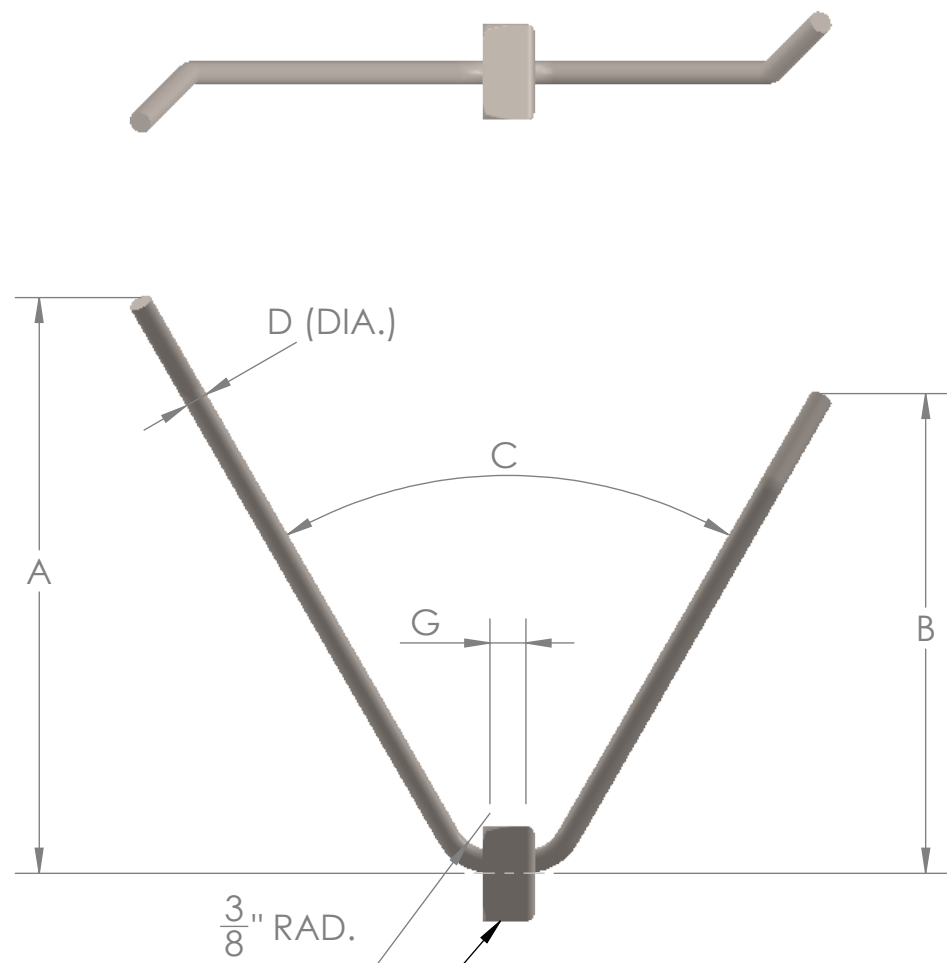

PROPRIETARY AND CONFIDENTIAL
 THE INFORMATION CONTAINED IN THIS DRAWING IS THE SOLE PROPERTY OF MALCO. ANY REPRODUCTION IN PART OR AS A WHOLE WITHOUT THE WRITTEN PERMISSION OF MALCO IS PROHIBITED.

		UNLESS OTHERWISE SPECIFIED:		NAME	DATE
		DIMENSIONS ARE IN INCHES		DRAWN	MW 12/8/25
		TOLERANCES:		CHECKED	
		FRACTIONAL: ±		ENG APPR.	
		ANGULAR: MACH ± BEND ±		MFG APPR.	
		TWO PLACE DECIMAL ±		Q.A.	
		THREE PLACE DECIMAL ±		COMMENTS:	
		INTERPRET GEOMETRIC TOLERANCING PER:			
		MATERIAL			
		Stainless steel			
		FINISH			
NEXT ASSY	USED ON				
APPLICATION		DO NOT SCALE DRAWING			
		TITLE:			
SIZE	DWG. NO.	REV			
B	AR-750	0			
SCALE: 1:2		WEIGHT:		SHEET 1 OF 1	