

4

3

2

1

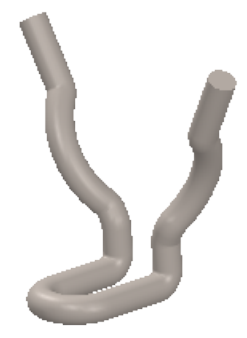
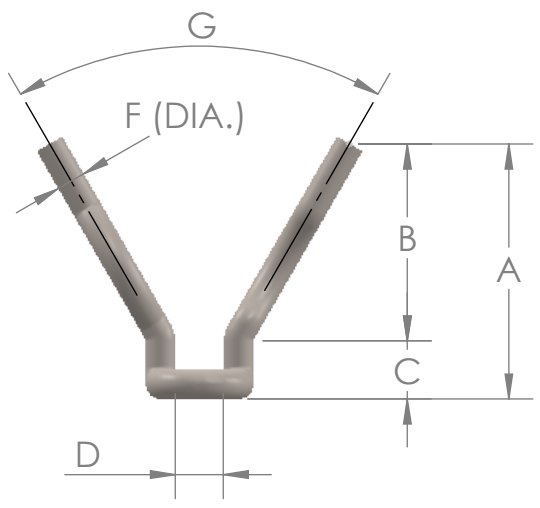
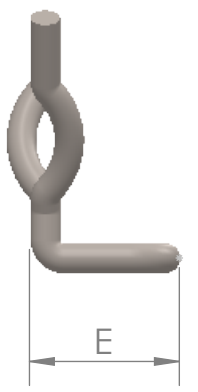

NO.	A	B	C	D	E	F	G
-1	2 5/8	2 1/8	1/2	.406	1 1/4	1/4	60°
-2	3 1/8	2 5/18	1/2	.406	1 1/4	1/4	60°
-3	4 1/8	3 1/8	1	.406	1 1/4	1/4	60°
-4	5 1/8	4 1/8	1	.406	1 1/4	1/4	60°
-5	6 1/8	5 1/8	1	.406	1 1/4	1/4	60°
-6	2 1/8	2 1/8	-	.406	1 1/4	5/16	60°
-7	2 1/2	2	1/2	.406	1 1/4	5/16	60°
-8	2 5/8	2 5/8	-	.406	1 1/4	5/16	60°
-9	3 1/8	3 1/8	-	.406	1 1/4	5/16	60°
-10	3 5/8	3 5/8	1	.406	1 1/4	5/16	60°
-11	3	2 1/2	1/2	.406	1 1/4	5/16	60°
-12	3 1/2	2 1/2	1	.406	1 1/4	5/16	60°
-13	4	3	1	.406	1 1/4	5/16	60°
-14	5 1/8	4 1/8	1	.406	1 1/4	5/16	60°
-15	6 1/8	5 1/8	1	.406	1 1/4	5/16	60°

**PROPRIETARY AND CONFIDENTIAL**  
 THE INFORMATION CONTAINED IN THIS DRAWING IS THE SOLE PROPERTY OF MALCO. ANY REPRODUCTION IN PART OR AS A WHOLE WITHOUT THE WRITTEN PERMISSION OF MALCO IS PROHIBITED.

		UNLESS OTHERWISE SPECIFIED:	NAME	DATE		
		DIMENSIONS ARE IN INCHES	DRAWN	MW	10/18/25	TITLE:
		TOLERANCES:	CHECKED			
		FRACTIONAL ±	ENG APPR.			
		ANGULAR: MACH ± BEND ±	MFG APPR.			
		TWO PLACE DECIMAL ±	Q.A.			
		THREE PLACE DECIMAL ±	COMMENTS:			SIZE
		INTERPRET GEOMETRIC TOLERANCING PER:				DWG. NO.
		MATERIAL				REV
		Stainless steel				<b>B</b>
NEXT ASSY	USED ON	FINISH				<b>AR-739</b>
APPLICATION		DO NOT SCALE DRAWING				<b>0</b>
						SCALE: 1:2
						WEIGHT:
						SHEET 1 OF 1

4

3

2

1

B

B

A

A