

4

3

2

1

NO.	A	B	C	D	E	R1	R2	S
-1	4 1/8	3 1/4	5/32	5/8	1/8	3/16	9/32	1 1/32
-2	6 1/8	3 1/4	5/32	5/8	1/8	3/16	9/32	1 1/32
-3	7 1/8	3 1/4	5/32	5/8	1/8	3/16	9/32	1 1/32
-4	5 1/2	4 5/8	5/32	5/8	1/8	3/16	9/32	1 1/32
-5	7 1/2	4 5/8	5/32	5/8	1/8	3/16	9/32	1 1/32
-6	8 1/2	4 5/8	5/32	5/8	1/8	3/16	9/32	1 1/32
-7	6 7/8	6	5/32	5/8	1/8	3/16	9/32	1 1/32
-8	8 7/8	6	5/32	5/8	1/8	3/16	9/32	1 1/32
-9	9 7/8	6	5/32	5/8	1/8	3/16	9/32	1 1/32

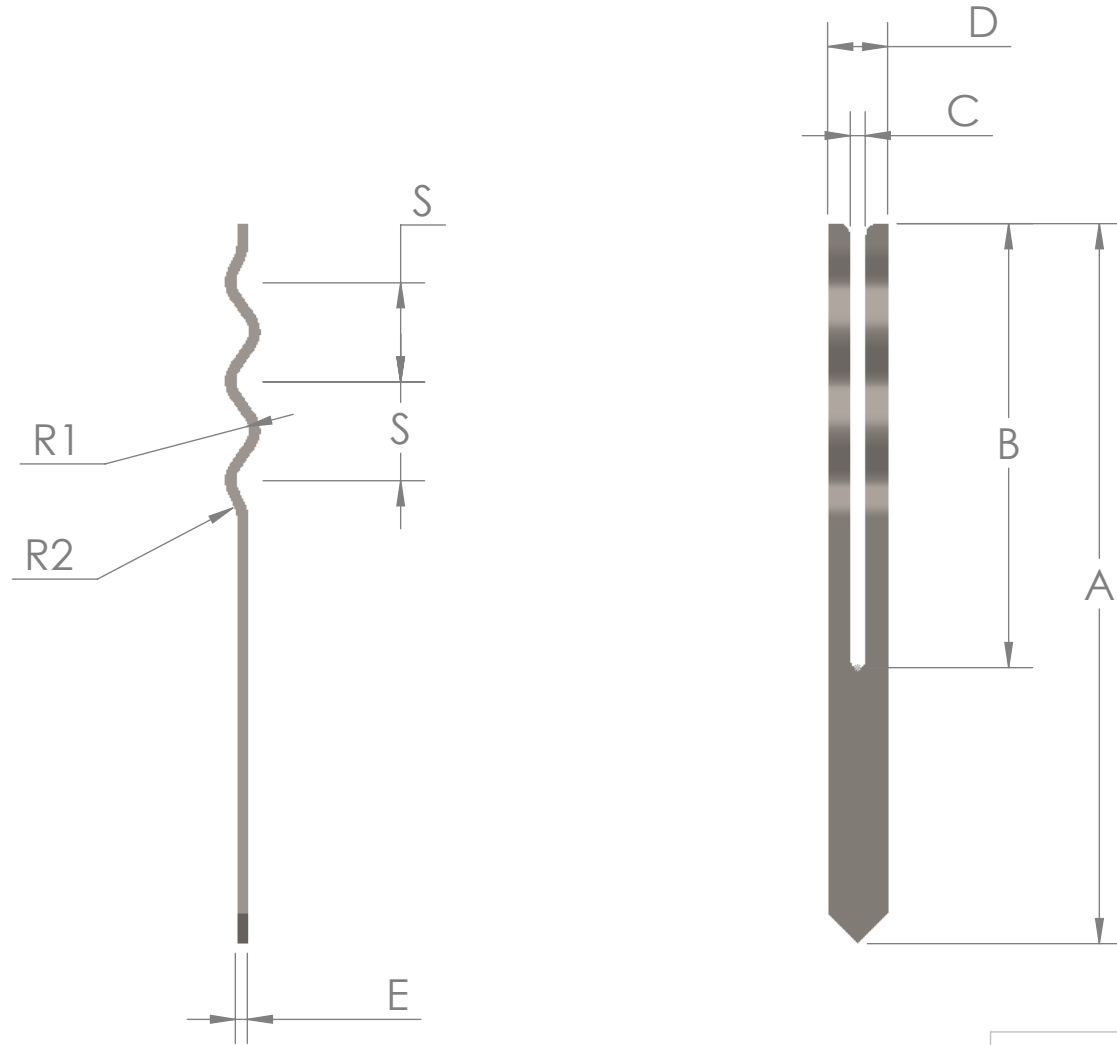

**PROPRIETARY AND CONFIDENTIAL**  
 THE INFORMATION CONTAINED IN THIS DRAWING IS THE SOLE PROPERTY OF MALCO. ANY REPRODUCTION IN PART OR AS A WHOLE WITHOUT THE WRITTEN PERMISSION OF MALCO IS PROHIBITED.

		UNLESS OTHERWISE SPECIFIED:		NAME	DATE
		DIMENSIONS ARE IN INCHES		DRAWN	MW 11/8/25
		TOLERANCES:		CHECKED	
		FRACTIONAL ±		ENG APPR.	
		ANGULAR: MACH ± BEND ±		MFG APPR.	
		TWO PLACE DECIMAL ±		Q.A.	
		THREE PLACE DECIMAL ±		COMMENTS:	
		INTERPRET GEOMETRIC TOLERANCING PER:			
		MATERIAL			
		Stainless steel			
		FINISH			
NEXT ASSY	USED ON				
APPLICATION		DO NOT SCALE DRAWING			
		TITLE:			
SIZE	DWG. NO.	REV			
<b>B</b>	AR-736	0			
SCALE: 1:2	WEIGHT:	SHEET 1 OF 1			

4

3

2

1